

UNCONTROLLED DOCUMENT

PART NUMBER  
SSF-LXH22573LIID

REV.  
D

REV.	E.C.N. NUMBER AND REVISION COMMENTS	DATE
A	UPDATED SAFE OPER SPECS.	9.12.95
B	E.C.N. #10336.	4.22.97
C	E.C.N. #10520.	6.8.99
D	E.C.N. #10BRDR. & REDRAWN.	5.10.01

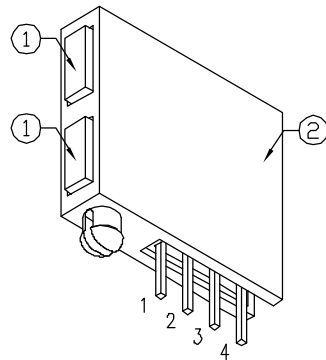
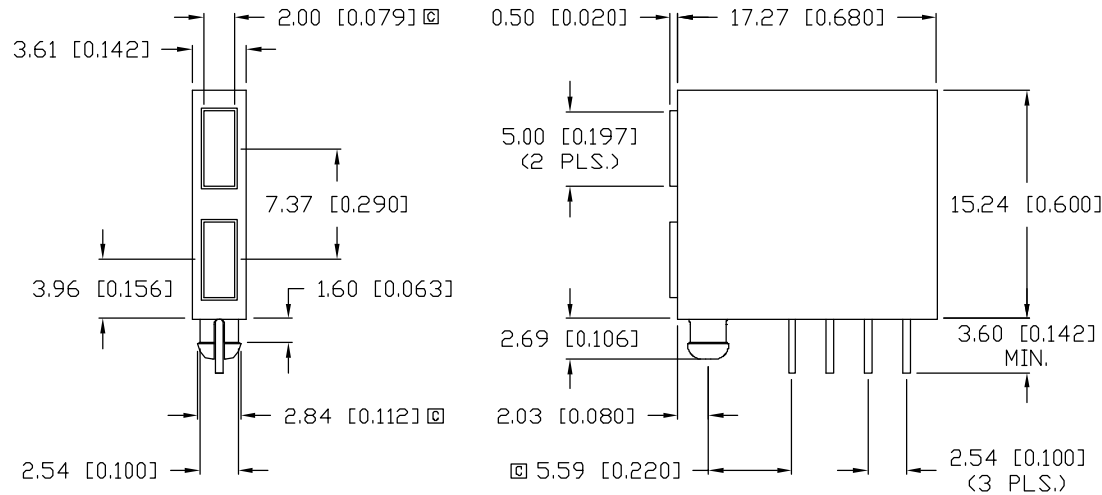

LEADS:

1. RED ANODE.
2. RED CATHODE.
3. RED ANODE.
4. RED CATHODE.

ELECTRO-OPTICAL CHARACTERISTICS  $T_A=25^\circ\text{C}$   $I_f=20\text{mA}$

PARAMETER	MIN	TYP	MAX	UNITS	TEST COND
PEAK WAVELENGTH		635		nm	
FORWARD VOLTAGE		2.0	2.5	$V_f$	
REVERSE VOLTAGE	5.0			$V_r$	$I_f=100\mu\text{A}$
AXIAL INTENSITY		10		mcd	$I_f=20\text{mA}$
		0.6		mcd	$I_f=2\text{mA}$
VIEWING ANGLE		80		$2x$ theta	
EMITTED COLOR:	RED				
EPOXY LENS FINISH:	RED DIFFUSED				

LIMITS OF SAFE OPERATION AT  $25^\circ\text{C}$  PER CHIP

PARAMETER	MAX	UNITS
PEAK FORWARD CURRENT*	150	mA
STEADY CURRENT	30	mA
POWER DISSIPATION	105	mW
DERATE FROM $25^\circ\text{C}$	-1.2	mW/ $^\circ\text{C}$
OPERATING, STORAGE TEMP.	-40 TO +85	$^\circ\text{C}$
SOLDERING TEMP.	+260	$^\circ\text{C}$
2.0mm FROM BODY		3 SEC. MAX

\*  $t < 10\mu\text{s}$

NOTES:

1. SSL-LX2573LIID, RED LED (2 PCS.).
2. SSH-LXH22573 HOLDER, BLACK.

UNCONTROLLED DOCUMENT

\*UNLESS OTHERWISE SPECIFIED TOLERANCES PER DECIMAL PRECISION ARE: X=±1 (±0.039), X.X=±0.5 (±0.020), X.XX=±0.25 (±0.010), X.XXX=±0.127 (±0.005). LEAD SIZE=±0.05 (±0.002), LEAD LENGTH=±0.75 (±0.030). MIN.= +DECIMAL PRECISION MAX.= +0.00 -DECIMAL PRECISION

REV. D	PART NUMBER SSF-LXH22573LIID
-----------	---------------------------------

CONFIDENTIAL INFORMATION  
THE INFORMATION CONTAINED IN THIS DOCUMENT IS THE PROPERTY OF LUMEX INC. EXCEPT AS SPECIFICALLY AUTHORIZED IN WRITING BY LUMEX INC., THE HOLDER OF THIS DOCUMENT SHALL KEEP ALL INFORMATION CONTAINED HEREIN CONFIDENTIAL AND SHALL PROTECT SAME IN WHOLE OR IN PART FROM DISCLOSURE AND DISSEMINATION TO ALL THIRD PARTIES.



290 E. HELEN ROAD  
PALATINE, IL 60067-6976  
PHONE: +1.847.359.2790  
US WEB: www.lumex.com  
TW WEB: www.lumex.com.tw

2mm x 5mm PIGGYBACK RIGHT ANGLE INDICATOR,  
LOW CURRENT SELECTION,  
TWO 635nm RED LEDS, RED DIFFUSED LENS.

RELIABILITY NOTE  
OUR MANY YEARS OF EXPERIENCE DATA ACCUMULATION INDICATE THAT SOLDER HEAT IS A MAJOR CAUSE OF EARLY AND FUTURE FAILURE. PLEASE PAY ATTENTION TO YOUR SOLDERING PROCESS.

DRAWN BY: CT	CHECKED BY:	APPROVED BY:	DATE: 9.8.93
			PAGE: 1 OF 1
			SCALE: N/A