

Mini-Z™ WLAN 28-Pin Module

RD000503-0814



Overview

The Mini-Z WLAN 28-Pin Module is a stand-alone 802.11 b/g TCP/IP Wireless Networking module that is produced in a 28-pin Dual Inline Pin package. The Mini-Z WLAN 28-Pin Module integrates Zilog's powerful ZNEO microcontroller with a Roving Networks 2.4GHz RN-171 802.11 b/g WiFly LAN Module.

Designed for the hobbyist, student and engineer to quickly develop prototypes, proof of concept and demonstrations as well as provide the functionality required for hands-on learning, the Module is designed to be pin-compatible with the Parallax BS2 Series of modules as well as with Basic-Micro-Technology's Basic ATOM Pro 28-M module. This flexibility allows you to utilize different vendor's base boards that you may already have in your arsenal.

The Module ships preprogrammed with a boot loader and a control shell that can be accessed through the serial port to allow control of the Module from a terminal program and upload your code hex file through the serial port. The Module is fully compatible with the ZDSII for ZNEO tools suite. You can write your programs in C and Assembly, then compile and upload the hex file through the serial port to the Module. You can also attach the USB Smart Cable (included in the Mini-Z WLAN SSR Kit) and have full control over the ZNEO chip, including interactive debugging sessions.

Mounting the Mini-Z WLAN 28-Pin Module

The Mini-Z WLAN 28-Pin Module is designed to plug into a base board such as the SSR Design Board, a key component of Zilog's [Mini-Z WLAN SSR Kit](#). Pin 1 on the Module must be aligned with Pin 1 on the design board. Pin 1 on the Module is located near the chamfered corner, as indicated in Figure 1.

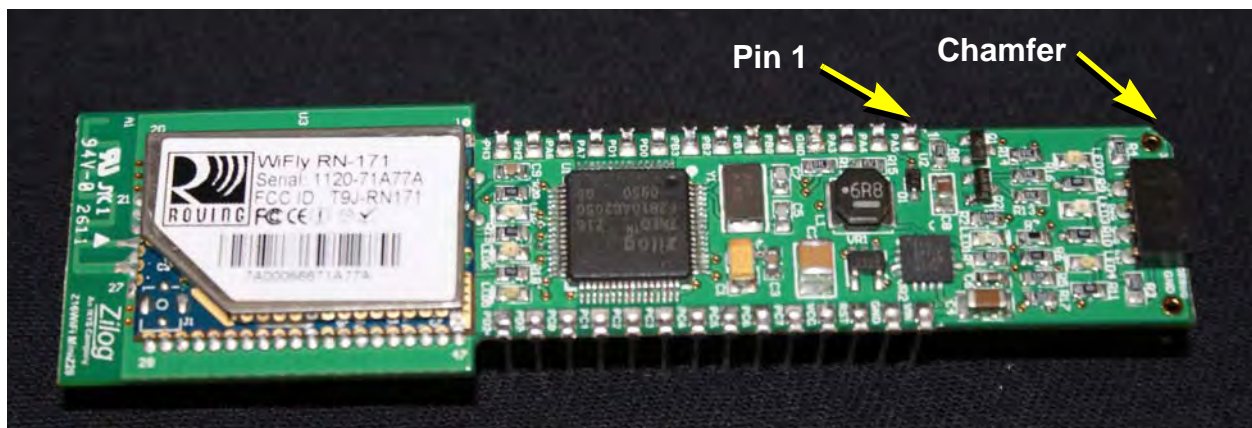

Figure 1. The ZNEO-Based Mini-Z WLAN 28-Pin Module

- **Note:** The Mini-Z Library file associated with this reference design, [RD0006-SC01.zip](#), is available for download on [zilog.com](#). This file has been tested with version 5.0.0 of ZDSII for ZNEO-powered MCUs. Subsequent releases of ZDSII may require you to modify the code supplied with this reference design.
-

Mini-Z WLAN 28-Pin Module Features

- Powerful 16-bit CISC microcontroller
- 128KB of Flash program space with 16-bit access and in-circuit programming
- 4KB internal RAM with 16 bit access
- 24-bit address space
- 24-bit stack with overflow protection
- Direct register-to-register architecture, allows each memory address to function as an accumulator. This improves execution time and decreases the required program memory
- 5.5V to 15V input with internal 5V and 3.3V regulation
- 4-channel, 10-bit ADC
- Analog Comparator
- Internal Precision Oscillator
- I²C Master/Slave Controller
- Enhanced Serial Peripheral Interface (ESPI)
- Three standard 16-bit timers with capture, compare and PWM capability
- 12-bit PWM module with three complementary pairs, or six independent PWM outputs, with deadband generation and fault trip input
- 24 interrupts with programmable priority
- Watchdog Timer with Internal RC Oscillator
- On-Chip Debugger
- Voltage Brown-Out protection (VBO)
- Power-On Reset (POR)
- Low power modes

Networking Support

- Secure wireless authentication
 - WEP-128
 - WPA-PSK(TKIP)
 - WPA2-PSK (AES)

- Built in networking applications:
 - DHCP
 - DNS
 - ICMP
 - HTML client
 - UDP
 - ARP
 - TCP
- 802.11 power save and roaming functions including intelligent built-in power management with programmable wake-up
- Software-controlled transmit power (0dBm to 12dBm) for ultra-low power applications

Module Pin Description

Table 1 describes the functions of each of the Mini-Z WLAN 28-Pin Module’s 28 pins.

Table 1. Mini-Z WLAN 28-Pin Module Pin-Out

Pin	Pin Name	ZNEO Pin Name	Base Function	Alternate Function 1	Alternate Function 2
1	S _{OUT}	PA5	MCU Transmit		
2	S _{IN}	PA4	MCU Receive		
3	DTR	PA3	CTS/DTR		
4	V _{SS}	GND	Ground		
5	PO	PB0	GPIO	ANA 0 (ADC)	TOIN0
6	P1	PB1	GPIO	ANA 1 (ADC)	TOIN1
7	P2	PB2	GPIO	ANA 2 (ADC)	TOIN2
8	P3	PB3	GPIO	ANA 3 (ADC)	OPOUT
9	P4	PD0	GPIO	PWMH1	
10	P5	PD1	GPIO	PWML1	
11	P6	PA7	GPIO	SDA	
12	P7	PA6	GPIO	SCL	
13	P16	PH2	GPIO	ANA10	
14	P17	PH3	GPIO	ANA11	CPINP
15	P18	PD2	GPIO	PWMH2	
16	P19	PD7	GPIO	PWML2	
17	P8	PC0	GPIO	T1IN/#T1OUT	CINN
18	P9	PC1	GPIO	T1OUT	COMPOUT
19	P10	PC2	GPIO	SS	
20	P11	PC3	GPIO	SCK	
21	P12	PC4	GPIO	MOSI	

Table 1. Mini-Z WLAN 28-Pin Module Pin-Out (Continued)

Pin	Pin Name	ZNEO Pin Name	Base Function	Alternate Function 1	Alternate Function 2
22	P13	PC5	GPIO	MISO	
23	P14	PC6	GPIO	T2IN/#T2OUT	PWMH0
24	P15	PC7	GPIO	T2OUT	PWML0
25	V _{CC} I/O	—	5V in/out		
26	Reset	Reset	Reset		
27	V _{SS}	GND	Ground		
28	V _{IN}	—	5.5–15V in		

Mini-Debug Connector

The Mini-Z WLAN 28-Pin Module uses a miniature debug connector (included in the [Mini-Z WLAN SSR Kit](#)) to connect to the smart cables and to ZDSII. Alternatively, you can build your own adapter.

The mini-debug adapter features a 4-pin single-row header; its pins are 2 mm apart, center to center. To connect the mini-debug adapter, wire a male header (equivalent to Molex part number 90120-0124) to a 6-pin (2x3) male header (equivalent to Molex 90131-0763) using the connections shown in Figure 2.

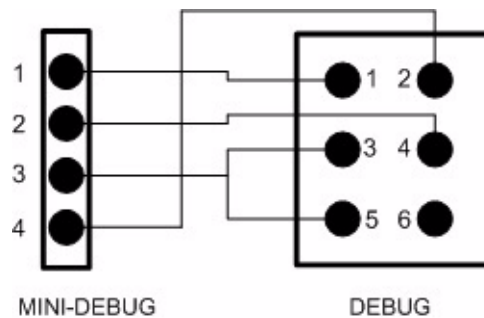

Figure 2. Mini-Debug to Debug Pin-Out

Electrical Characteristics

Tables 2 and 3 describe the electrical and power consumption characteristics, respectively, of the Mini-Z WLAN 28-Pin Module, and reflect all available data as a result of testing prior to qualification and characterization. As such, the data presented in these tables are subject to change.

► **Note:** Stresses greater than those listed in Table 2 may cause permanent damage to the device. These ratings are stress ratings only. Operation of the device at any condi-

tion outside those indicated in the operational sections of these specifications is not implied. Exposure to absolute maximum rating conditions for extended periods affects device reliability. For improved reliability, unused inputs must be tied to one of the supply voltages (V_{DD} or V_{SS}).

Table 2. Mini-Z WLAN 28-Pin Module Characteristics

Parameter	Min	Max	Units	Notes
V_{IN} Range	5.5	15	Volts	
Max Voltage Range for Serial Interface	-15	15	Volts	Pin 1, 2 & 3.
Max Voltage range, all other pins	-0.3	5.5	Volts	I/O pins and Reset.
V_{CC} I/O Range	4.8	5.1	Volts	
Max Current for I/O pins	-25	25	Milliamps (mA)	
Max Current on input/inactive output	-5	5	Microamps (μ A)	
Max Dissipation		540	Milliwatts (mW)	
Max Current		134	Milliamps (mA)	With respect to the ZNEO MCU, not including V_{CC} I/O.
Max Current out on V_{CC} I/O		100	Milliamps (mA)	
Low-level input	-0.3	1.08	Volts	
High-level input	2.5	3.6	Volts	
Low-level output	0	.6	Volts	
High-level output	2.4	3.3	Volts	
I/O leakage current	-5	5	Microamp (μ A)	
Internal V_{REF}	1.9	2.1	Volts	2V, typical.
Ambient temperature	-40	105	Degrees Celsius	
Storage temperature	-65	150	Degrees Celsius	

Table 3. WiFly LAN Module Power Consumption

State	Typical	Units
Sleep	4	Microamps (mA)
Standby (doze)	15	Milliamps (mA)
Connected (idle, RX)	40	Milliamps (mA)

Note: The transmit power can be controlled via firmware.

Table 3. WiFly LAN Module Power Consumption

State	Typical	Units
Connected (TX)*		
0dBm	120	Milliamps (mA)
12dBm	190	Milliamps (mA)

Note: The transmit power can be controlled via firmware.

Ordering Information

The Mini-Z WLAN 28-Pin Module can be ordered from the [Zilog Store](#) using the part number listed in Table 4.

Table 4. Mini-Z WLAN 28-Pin Module Ordering Information

Part Number	Description	Store Product ID
Z16F28WF100MODG	Mini-Z WLAN 28-Pin Module	RD10003
Z16F28WF100KITG	Mini-Z WLAN 28-Pin SSR Kit	RD10006

Kit Contents

The Mini-Z WLAN SSR Kit contains the following elements:

- Mini-Z WLAN 28-Pin Module
- Mini-Z Solid State Relay Design Board
- USB Smart Cable
- Mini-Z to standard debug adapter
- USB cable (A male to Mini-B male)
- DIP Package Extractor

Related Documentation

The documents associated with the Mini-Z WLAN 28-Pin Module are listed in Table 5. Each of these documents can be obtained from the Zilog website (except where noted) by clicking the link associated with its Document Number.

Table 5. ZAURA RF Wireless Module Documentation

Document Number	Description
RD0005	This Mini-Z WLAN 28-Pin Module Reference Design document
RD0006-SC01	Mini-Z Library
QS0084	Mini-Z WLAN 28-Pin Module Quick Start Guide
RM0062	Mini-Z WLAN Shell and Flash Loader Reference Manual
UM0238	Mini-Z WLAN 28-Pin Module Test and Assembly Procedure User Manual
RD0006	Mini-Z ZNEO 28-Pin Module Reference Design document
PS0220	ZNEO Z16F Series Product Specification
UM0188	ZNEO CPU Core User Manual
UM0181	USB Smart Cable User Manual
RN website	Roving Networks RN-171 Data Sheet
RN website	Roving Networks WiFly ESX User Manual and Command Reference

Appendix A. Schematic Diagram

Figure 4 shows a schematic diagram of the Mini-Z WLAN 28-Pin Module.

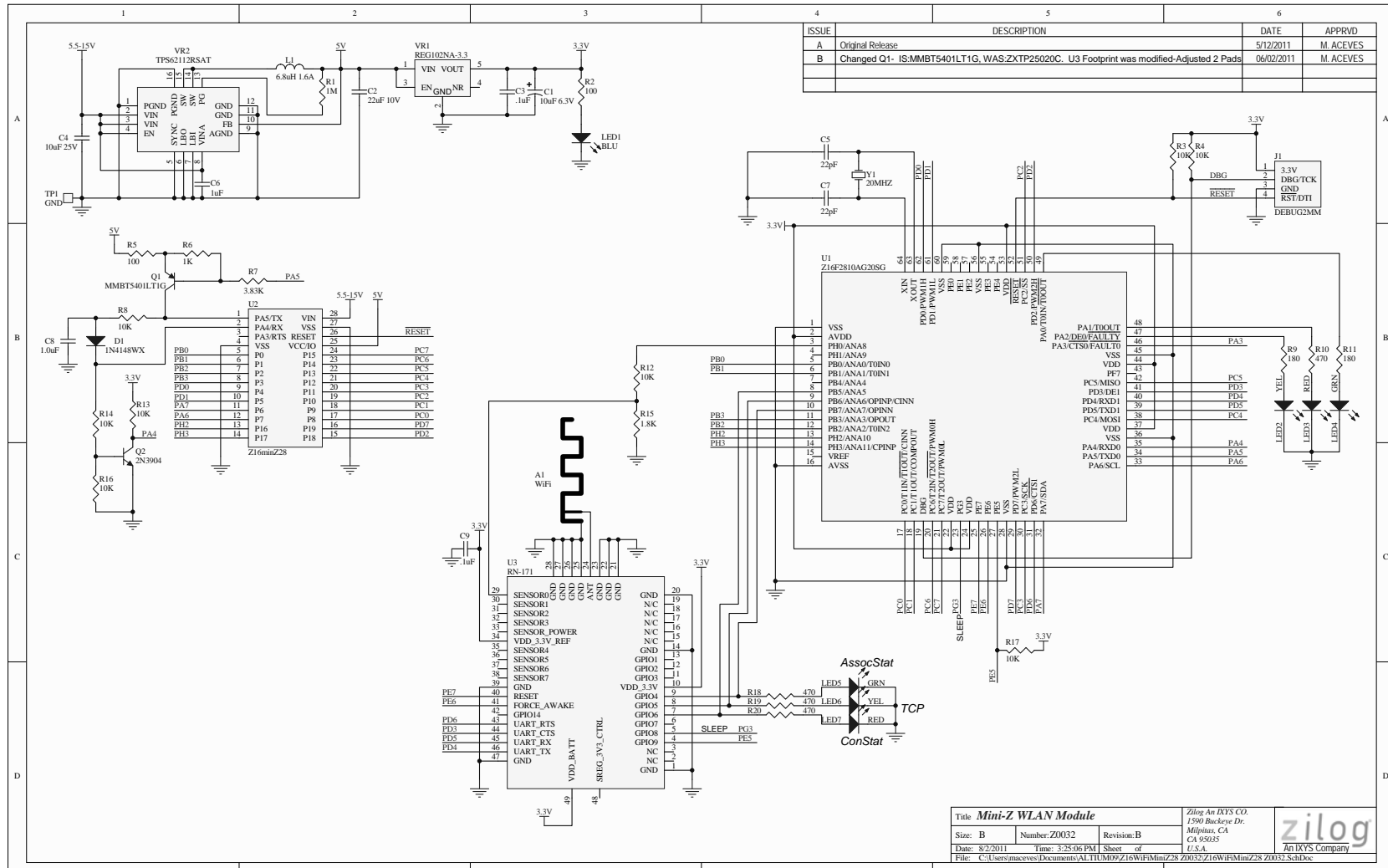

Figure 4. Mini-Z WLAN 28-Pin Module Schematics

Customer Support

To learn more about this product, find additional documentation, get your technical questions answered or report issues, please contact esales@zilog.com.



Warning: DO NOT USE THIS PRODUCT IN LIFE SUPPORT SYSTEMS.

LIFE SUPPORT POLICY

ZILOG'S PRODUCTS ARE NOT AUTHORIZED FOR USE AS CRITICAL COMPONENTS IN LIFE SUPPORT DEVICES OR SYSTEMS WITHOUT THE EXPRESS PRIOR WRITTEN APPROVAL OF THE PRESIDENT AND GENERAL COUNSEL OF ZILOG CORPORATION.

As used herein

Life support devices or systems are devices which (a) are intended for surgical implant into the body, or (b) support or sustain life and whose failure to perform when properly used in accordance with instructions for use provided in the labeling can be reasonably expected to result in a significant injury to the user. A critical component is any component in a life support device or system whose failure to perform can be reasonably expected to cause the failure of the life support device or system or to affect its safety or effectiveness.

Document Disclaimer

©2014 Zilog, Inc. All rights reserved. Information in this publication concerning the devices, applications, or technology described is intended to suggest possible uses and may be superseded. ZILOG, INC. DOES NOT ASSUME LIABILITY FOR OR PROVIDE A REPRESENTATION OF ACCURACY OF THE INFORMATION, DEVICES, OR TECHNOLOGY DESCRIBED IN THIS DOCUMENT. ZILOG ALSO DOES NOT ASSUME LIABILITY FOR INTELLECTUAL PROPERTY INFRINGEMENT RELATED IN ANY MANNER TO USE OF INFORMATION, DEVICES, OR TECHNOLOGY DESCRIBED HEREIN OR OTHERWISE. The information contained within this document has been verified according to the general principles of electrical and mechanical engineering.

ZNEO and Mini-Z are trademarks or registered trademarks of Zilog, Inc. All other product or service names are the property of their respective owners.