

© 1960 BY AMP INCORPORATED. ALL RIGHTS RESERVED. AMP PRODUCTS COVERED BY PATENTS AND/OR PATENTS PENDING.

REVISIONS				
ZONE	LTR	DESCRIPTION	DATE	APPROVED
	C	REDRAWN, UPDATED & ADDED 2-322010-3 ^M NPS 68-0659 (REV 2)	8-14-69	JME
	D	PER ECN P-7000	12-12-71	CEW
	E	INACTIVE, REACTIVE 2-322010-1 PER P-9263 & P-9346 INACTIVATED 2-322010-2 & 2-3 P-9263	3-17-82	DDT/DJM
	F	2--1 INACTIVE PER P-9909	APF 3-2-83	2
	G	OBS. 2-1, 2-2, 2-3 / G-2409	Ø 3-18-87	
	H	REV G-4680	TMS 5-6-88	ST

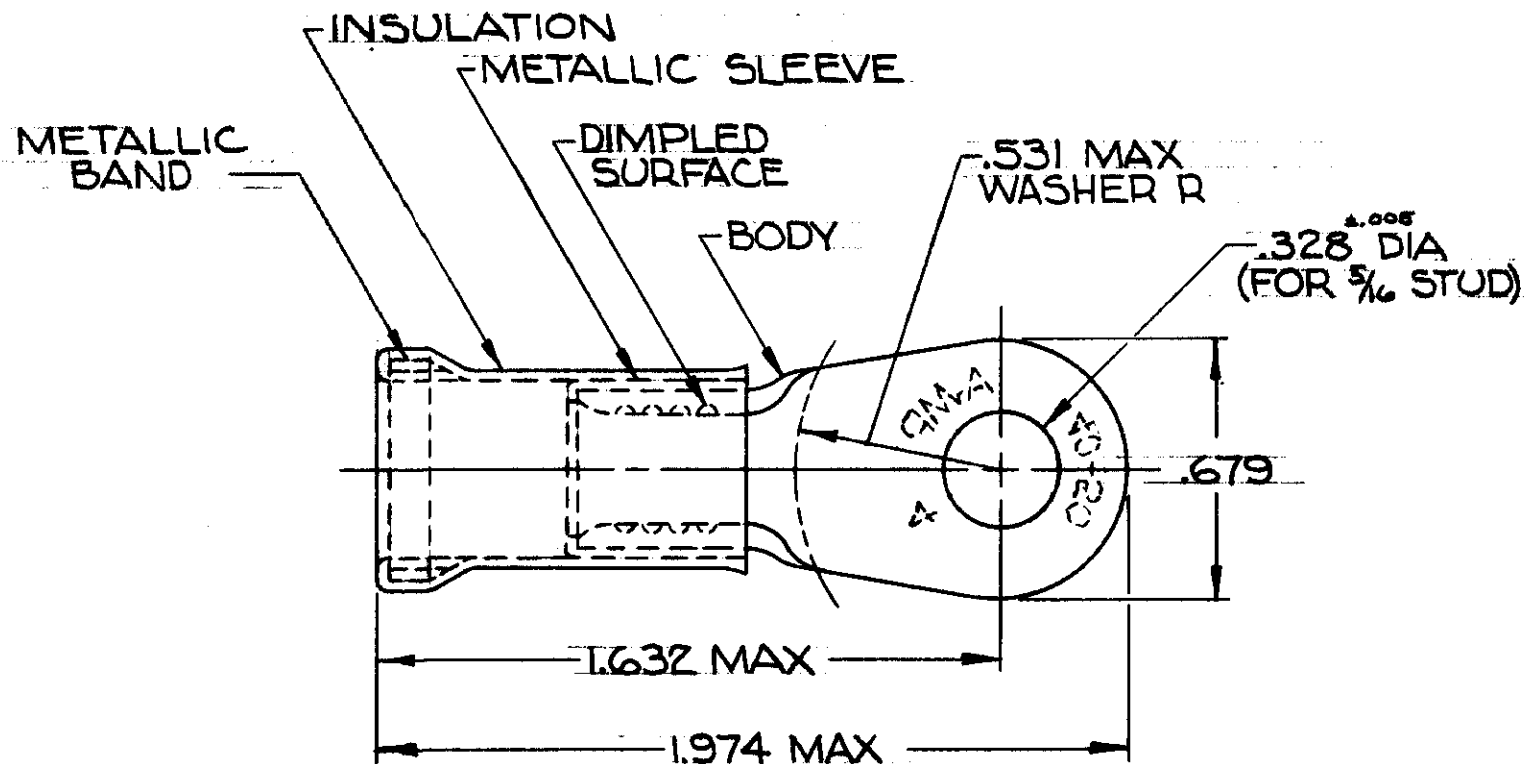

1. TIN PL (MIL-T-10727)
2. SILVER PL (QQ-5-365) .0002 MIN EXT THK
3. GOLD PL (MIL-G-45204) TYPE II .00005 MIN EXT THK OVER
NICKEL PL (QQ-N-290) .00003 MIN EXT THK

FOR "A" MAX WIRE INSULATION DIA.
TONGUE MATERIAL THK. = .048 ±.003

	TAPE MOUNTED	2-322010-4	322010
T	WIRE TERMINAL	SEE TABLE II	METALLIC BAND: STEEL QQ-5-698 (ASTM A109)
			INSULATION: YELLOW PVC
			METALLIC SLEEVE: COPPER (QQ-C-576)
			BODY: COPPER (QQ-C-576) FINISH: SEE TABLE II
QTY	DESCRIPTION	PART NO.	MATERIAL & FINISH
UNLESS OTHERWISE SPECIFIED DIMENSIONS ARE IN INCHES		CONTRACT NO. —H—	AMP INCORPORATED HARRISBURG, PENNSYLVANIA
TOLERANCES ON: DECIMALS ±.008 ANGLES ±5°		DR. <i>P.C. Young</i> 8-12-69	
MATERIAL	CHK	<i>J.M. Enominger</i> 8-14-69	NAME WIRE TERMINAL
	APPD	<i>Swibel</i> 8-15-69	AMPLI-BOND-RING TONGUE
	REL	<i>J.M. Enominger</i> 8-18-69	WIRE SIZE: 4
	DSGN APPD		SIZE B
SEE TABLE I	OTHER APPD		CODE IDENT NO. 00779
			NUMBER 322010
			SCALE 2:1
			SHEET 1 OF 1

TABLE II

2-322010-3	NOTE 1	.505
2-322010-2	NOTE 3	
2-322010-1	NOTE 2	.436
322010	NOTE 1	
PART NO.	FINISH	"A"

←←← OBSOLETE