

DRAWING MADE IN THIRD ANGLE PROJECTION

THIS DRAWING IS UNPUBLISHED. RELEASED FOR PUBLICATION .19

© COPYRIGHT 19 BY AMP INCORPORATED. ALL INTERNATIONAL RIGHTS RESERVED.

LOC	DIST	REVISIONS						
DF	TO	P	F	ZONE	LTR	DESCRIPTION	DATE	APPD
				A		REV PER ECN DF-1043	10-17-88	DES JMN
				B		REV PER ECN DF-1335	1-14-89	DES JMN
				C		REV PER ECN DF-1390	2-2-89	DES JMN

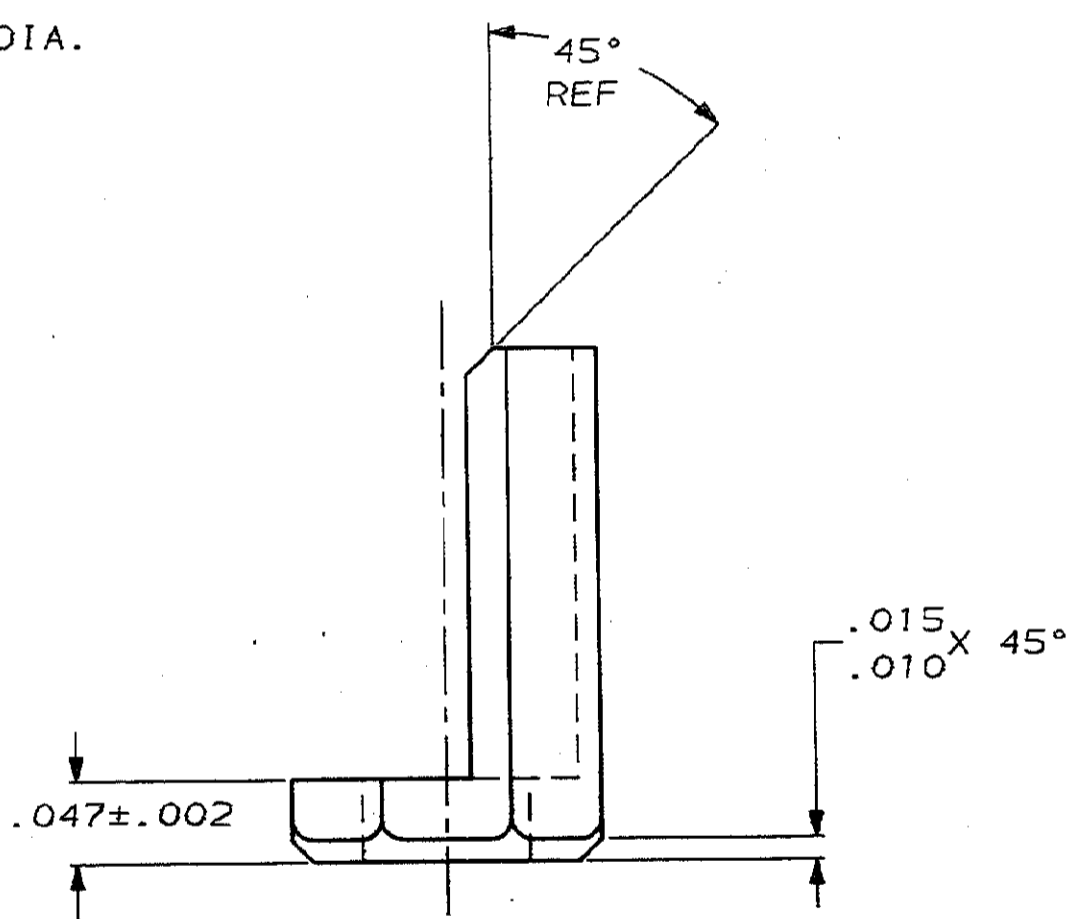
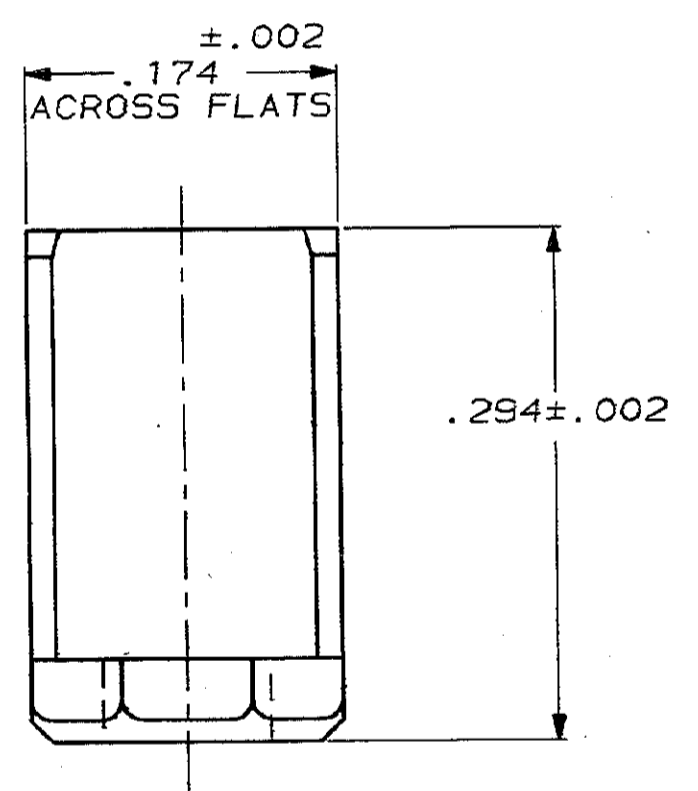
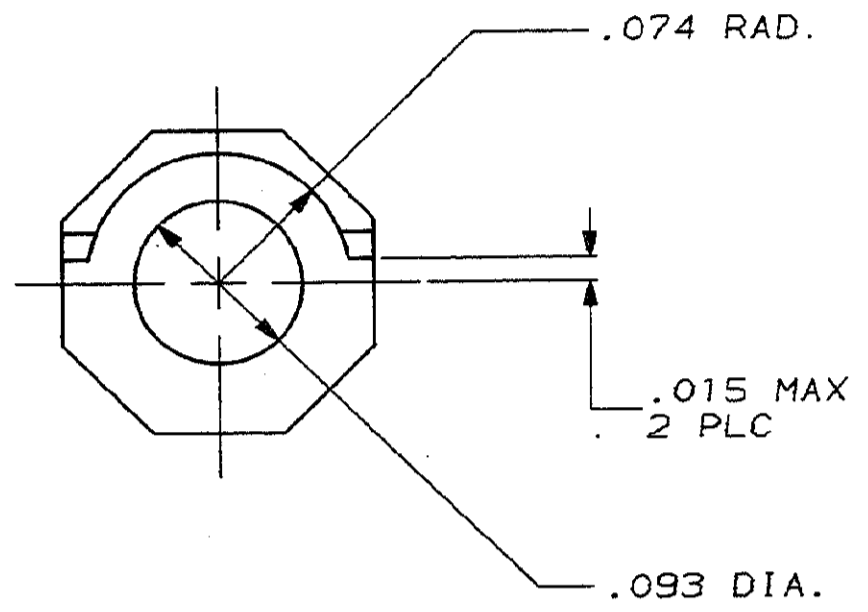

- 1 MATERIAL: STAINLESS STEEL PER ASTM-A-582.
- 2 PASSIVATED PER QQ-P-35.

445282-1

PART NO

DO NOT SCALE PRINT. UNLESS SPECIFIED DIMENSIONS IN INCHES TOLERANCES ON: 2 PLC DEC ± - 3 PLC DEC ± .005 ANGLES ± 1°	DR D.E. STAHL 9/12/88	AMP INCORPORATED Harrisburg, Pa. 17105	
	CHK J.M. NORTON 9/12/88		
MATERIAL 1	APPD J.M. NORTON 9/12/88	NAME KEY, EXTERNAL	
	APPD K.N. AYER 9/12/88	HDI-6 ROW	
FINISH 2	PRODUCT SPEC -	SIZE C	FSCM NO 00779
	APPLICATION SPEC -	DRAWING NO 445282	
	WEIGHT -	SCALE -	SHEET 1 OF 1

CUSTOMER DRAWING