

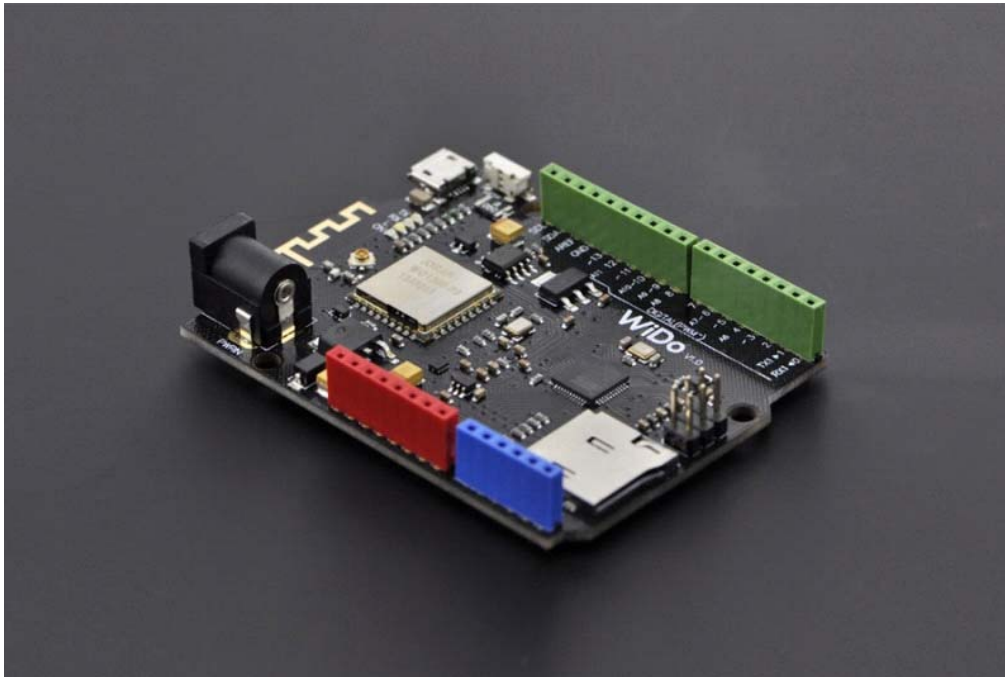

Wido-WIFI IoT Node SKU:DFR0321

From Robot Wiki



Contents

- 1 Introduction
- 2 Specification
- 3 Application
- 4 PinOut
- 5 Tutorial
 - 5.1 Tutorial 1
 - 5.1.1 Step 1
 - 5.1.2 Step 2
 - 5.2 Tutorial 2
 - 5.2.1 Step 1
 - 5.2.2 Step 2
 - 5.3 Tutorial 3
 - 5.3.1 Step 1
 - 5.3.2 Step 2
- 6 Trouble shooting

Introduction

Wido is an Arduino compatible WIFI IoT Node development board, which integrates with WG1300 WIFI solution. The microcontroller of Wido is ATMEL ATmega32U4.

Specification

- Power Supply range: 5v or 7-12v
- Arduino Leonardo Compatible
- Integrate with WG1300 WIFI chip and support 2.4GHz IEEE 802.11 b/g network
- WiFi and MicroSD driven by SPI port
- On board 2.4G PCB Antenna
- Driver pins:
 - WiFi Module-D7(IRQ),D5(VBAT),D10(CS),D14(MISO),D15(SCK),D16(MOSI)
 - MicroSD-D4(CS),D14(MISO),D15(SCK),D16(MOSI)

Application

- M2M Sensor Node development
- Toys
- Gaming
- smart Home Device

PinOut

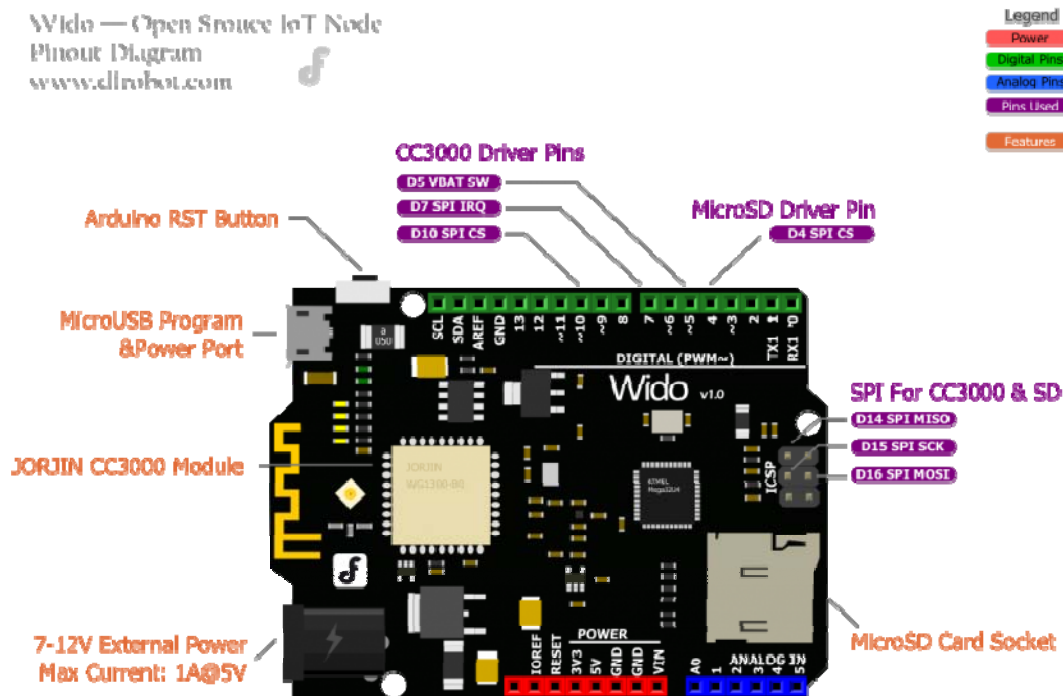

Fig1: Wido Pin Out

Tutorial

Tutorial 1

First of all, we will bring you a step by step tutorial to lead finish the Wido router connection configuration and make it work as a TCP client connected to the local server.

Step 1

- Wido 1unit
- MicroUSB Cable 1unit

Step 2

1. Install the [Arduino library](#) to your Arduino IDE. This library for Wido is forked from Adafruit. They've finished an awesome project for this CC3000 development. Based on this library, we updated the pin configuration and extended some application sample codes. [For more details from Github](#)

2. Open the sample code, which is named buildtest.

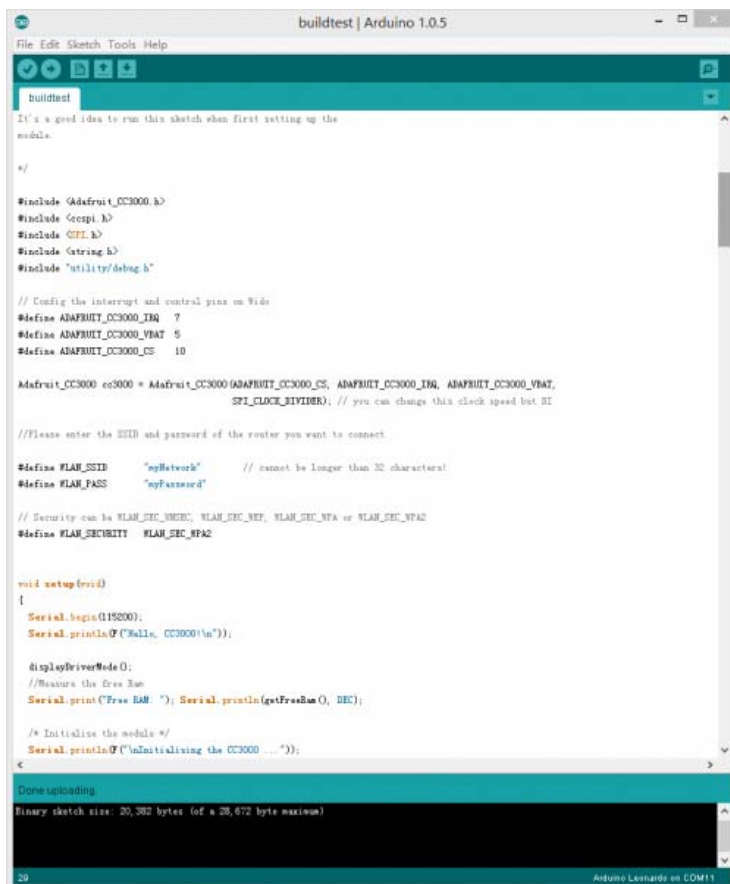

```
buildtest | Arduino 1.0.5
File Edit Sketch Tools Help
buildtest
It's a good idea to run this sketch when first setting up the module.

*/

#include <Adafruit_CC3000.h>
#include <ccspi.h>
#include <SPI.h>
#include <string.h>
#include <utility/debug.h>

// Config the interrupt and control pins on Wido
#define ADAFRUIT_CC3000_IRQ 7
#define ADAFRUIT_CC3000_VBAT 5
#define ADAFRUIT_CC3000_CS 10

Adafruit_CC3000 cc3000 = Adafruit_CC3000(ADAFRUIT_CC3000_CS, ADAFRUIT_CC3000_IRQ, ADAFRUIT_CC3000_VBAT,
SPI_CLOCK_DIVIDER); // you can change this clock speed but BE

//Please enter the SSID and password of the router you want to connect.

#define WLAN_SSID "myNetwork" // cannot be longer than 32 characters!
#define WLAN_PASS "myPassword"

// Security can be WLAN_SEC_WEP, WLAN_SEC_WEP, WLAN_SEC_WPA or WLAN_SEC_WPA2
#define WLAN_SECURITY WLAN_SEC_WPA2

void setup(void)
{
  Serial.begin(115200);
  Serial.println(F("Hello, CC3000!\n"));

  displayDriverMode();
  //Measures the Free Ram
  Serial.print("Free RAM: "); Serial.println(getFreeRam(), DEC);

  /* Initialize the module */
  Serial.println(F("Initializing the CC3000 ..."));
}

Done uploading
Binary sketch size: 20,382 bytes (of a 28,672 byte maximum)
Arduino Leonardo on COM11
```

Fig2: buildtest

3. Upload the sample code to Wido and check the Serial monitor after programming.

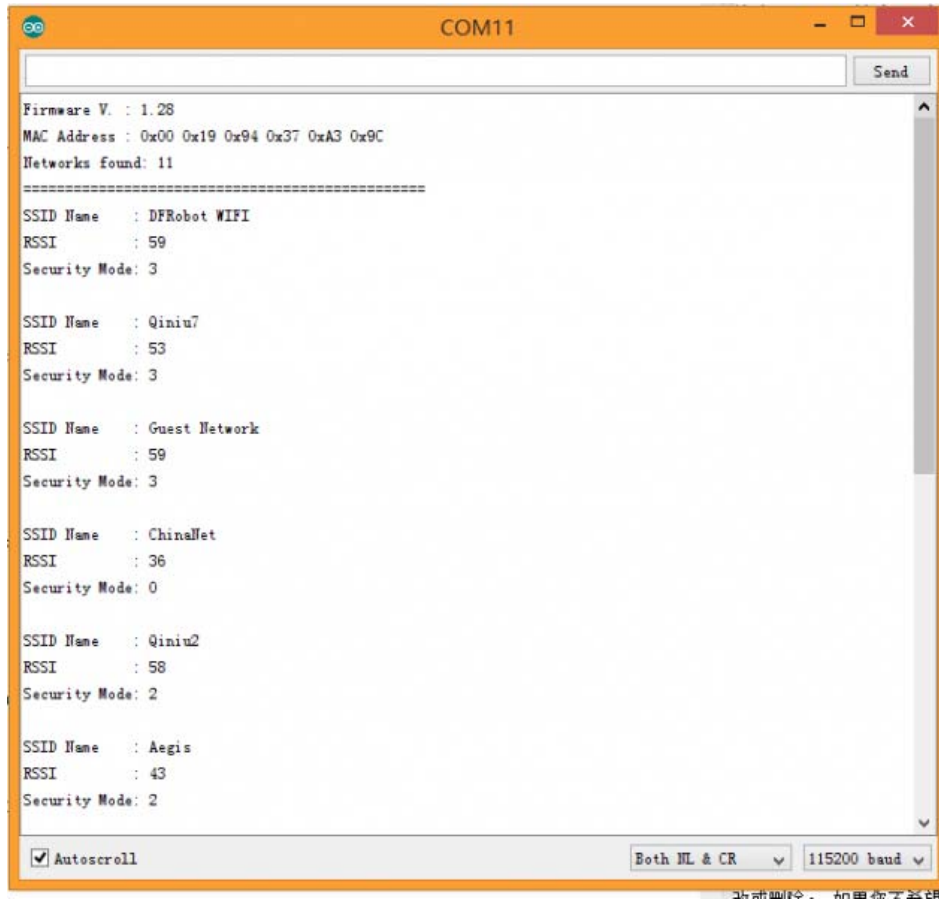

Fig3: Scan the Routers

You will see the information printed including the MAC address and local router information detected by Wido.

4. Update the SSID and password configuration in your code!

```
//Please enter the SSID and password of the router you want to connect  
#define WLAN_SSID      "myNetwork"          // cannot be longer than 32 characters!  
#define WLAN_PASS      "myPassword"
```

5. Then upload the sample sketch again. And after several seconds. You will see the effect, like the picture attached.

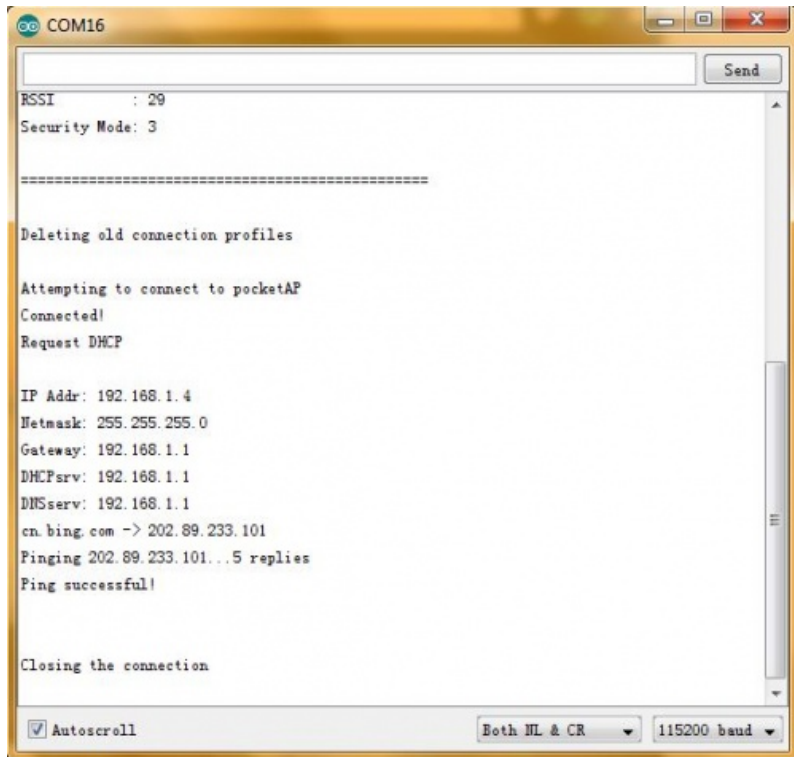

Fig4: Ping bing.com

Tutorial 2

Step 1

- [TCP Server Tool](#), used to create a local TCP server from your PC

Step 2

1. Open the Tool above. Config the port number, and click listening to wait for the client connection.

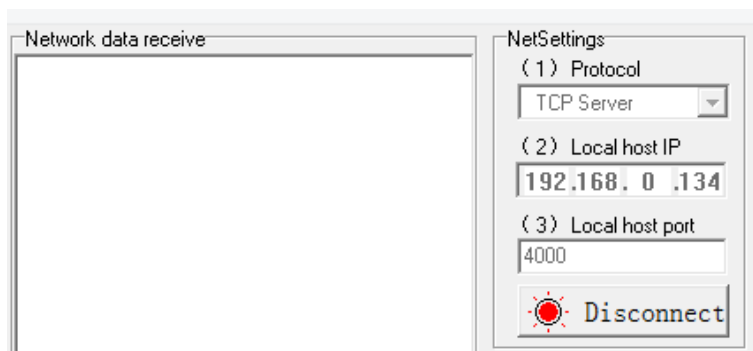

Fig1: Open TCP Server

2. Open the sketch named "Wido2LocalTcpServer", and config the TCP server address and port according to your tool setup.

```
/* Set the target ip address and connection port */
uint32_t ip = WiDo.IP2U32(192,168,0,134);
tcpClient = WiDo.connectTCP(ip, 9000);
```

Upload the full sample after TCP/Router configuration.

```
#include <Adafruit_CC3000.h>
#include <ccspi.h>
#include <SPI.h>
#include <string.h>
#include "utility/debug.h"

#define WiDo_IRQ    7
#define WiDo_VBAT  5
#define WiDo_CS     10
Adafruit_CC3000 WiDo = Adafruit_CC3000(WiDo_CS, WiDo_IRQ, WiDo_VBAT,
                                         SPI_CLOCK_DIVIDER); // you can change
e this clock speed

#define WLAN_SSID      "myNetwork"           // cannot be longer than 32 characters!
#define WLAN_PASS      "myPassword"

// Security can be WLAN_SEC_UNSEC, WLAN_SEC_WEP, WLAN_SEC_WPA or WLAN_SEC_WPA2
#define WLAN_SECURITY  WLAN_SEC_WPA2
#define TIMEOUT_MS    1000

void setup(){

  Serial.begin(115200);

  /* Initialise the module */
```

```

Serial.println(F("\nInitialising the CC3000 ..."));
if (!WiDo.begin())
{
  Serial.println(F("Unable to initialise the CC3000! Check your wiring?"));
  while(1);
}

/* NOTE: Secure connections are not available in 'Tiny' mode!
   By default connectToAP will retry indefinitely, however you can pass an
   optional maximum number of retries (greater than zero) as the fourth par
   ameter.
*/

Serial.println(F("Connecting Router/AP"));
if (!WiDo.connectToAP(WLAN_SSID, WLAN_PASS, WLAN_SECURITY)) {
  Serial.println(F("Failed!"));
  while(1);
}

Serial.println(F("Router/AP Connected!"));

/* Wait for DHCP to complete */
Serial.println(F("Request DHCP"));
while (!WiDo.checkDHCP())
{
  delay(100); // ToDo: Insert a DHCP timeout!
}
}

void loop(){

  static Adafruit_CC3000_Client tcpClient;
  static unsigned long heartRate = millis();

```

```

if(!tcpClient.connected()){
  Serial.println("Try to connect the Local Server");
  tcpClient.close();

  /* Set the target ip address and connection port */
  uint32_t ip = WiDo.IP2U32(192,168,0,134);
  tcpClient = WiDo.connectTCP(ip, 4000);

  if(!tcpClient.connected()){
    Serial.println(F("Couldn't connect to server! Make sure TCP Test Tool is
running on the server."));
    while(1);
  }
}
else if(millis() - heartRate > 1000){
  heartRate = millis(); // Update time stamp of the microcontroller system

  char clientString[30];
  sprintf(clientString, "%s%d%s", "Wido heartRate: ",heartRate/1000," s\r\n
");

  Serial.println(clientString);
  tcpClient.fastrprintln(clientString);
}

/* Read data until either the connection is closed, or the timeout is reach
ed. */
unsigned long lastRead = millis();
while (tcpClient.connected() && (millis() - lastRead < TIMEOUT_MS)) {
  while (tcpClient.available()) {
    char c = tcpClient.read();
    Serial.print(c);
    lastRead = millis();

    // Disable sending message for a moment

```



```

    heartRate = millis();
  }
}

```

```

}

```

3. Open the serial monitor. After connecting the router, your Wido will start to upload data to the TCP server tool!

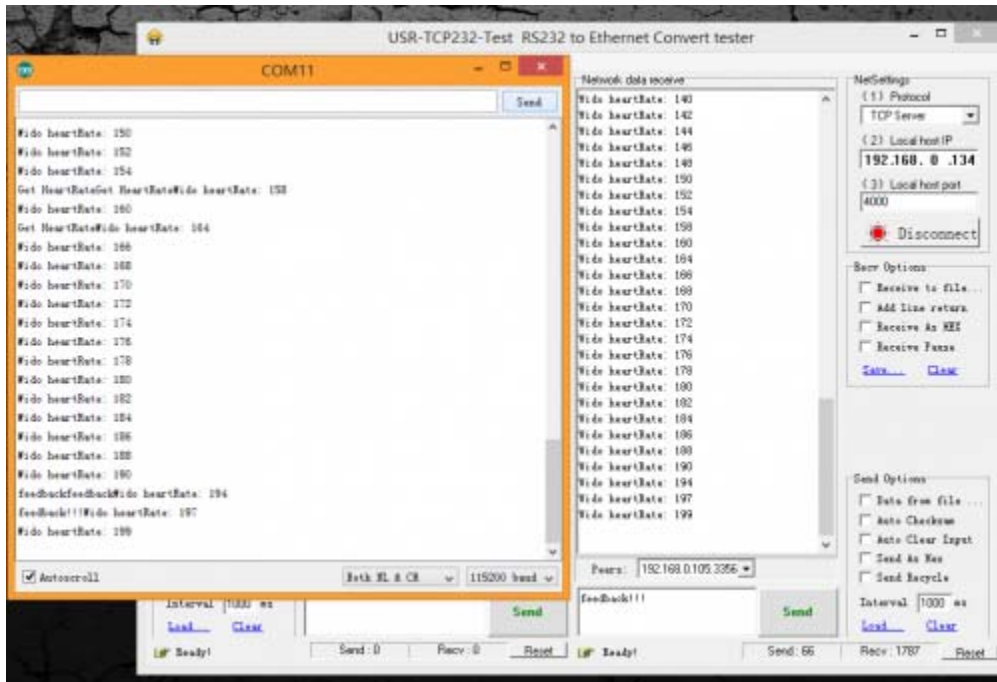

Fig1: Open TCP Server

Finish the local server connection and communication now. You get the access to build a WIFI controlled robot with Wido or some local cloud service project. But it's not enough for most of WIFI application!

Tutorial 3

Xively (formerly Cosm) is a Platform as a Service that provides everything you need to simplify and accelerate the creation of compelling connected products and solutions. In this section, we will bring your sensor to the **cloud**.☺

Step 1

1. Create your own Xively account and login the develop page. Create the a new device.
xively.com

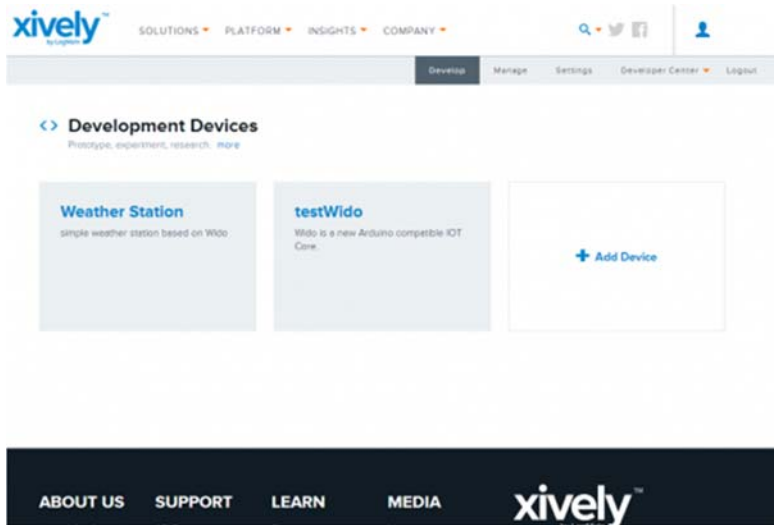

Fig1: Create Xively Account

2. Cick and enter your device.

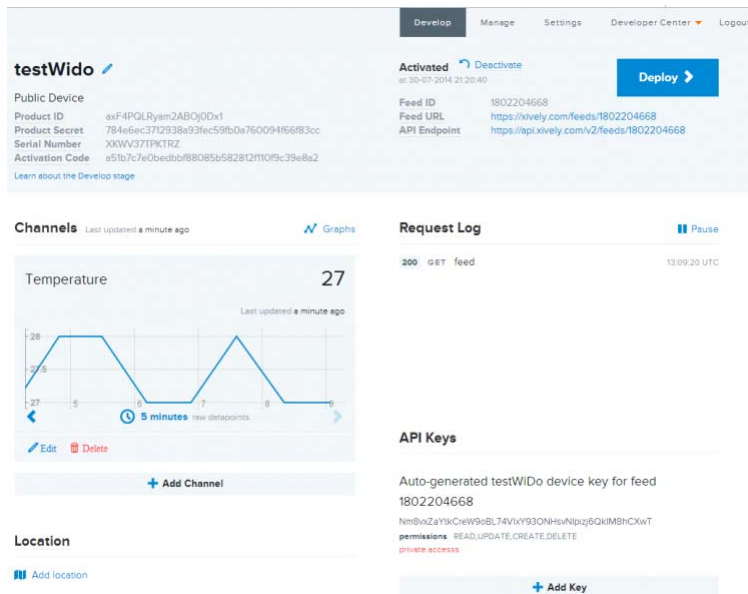

Fig2: Open the device page

3. Open the example code named "Wido2Xively" included in the Arduino library. Modify the info below in the sample code according to the device information from the step 2.

```
#define WEBSITE "api.xively.com"

#define API_key "Nm8vxZaYtkCreW9oBL74VIxY93ONHsvNlpizj6QkIM8hxxxx" // Check
your API Key from device page

#define feedID "180220xxxx" // Check
your feedID
```

The sample code:

```
/*
*****

* This is an example for the DFRobot Wido - Wifi Integrated IoT lite sensor
and control node

*
* Designed specifically to work with the DFRobot Wido products:
*
*
* The main library is forked from Adafruit
*
* Written by Lauren
* BSD license, all text above must be included in any redistribution
*
*****/

/*
This example code is used to connect the Xively cloud service.

The device required is just:

1. LM35 low cost temperature sensor or any device you used to upload data
2. And Wido

*/
```

```

#include <Adafruit_CC3000.h>
#include <ccspi.h>
#include <SPI.h>

#define Wido_IRQ    7
#define Wido_VBAT   5
#define Wido_CS     10
Adafruit_CC3000 Wido = Adafruit_CC3000(Wido_CS, Wido_IRQ, Wido_VBAT,
SPI_CLOCK_DIVIDER); // you can change this clock speed

#define WLAN_SSID      "myNetwork"           // cannot be longer than 32 cha
racters!
#define WLAN_PASS      "myPassword"
// Security can be WLAN_SEC_UNSEC, WLAN_SEC_WEP, WLAN_SEC_WPA or WLAN_SEC_WPA
2
#define WLAN_SECURITY  WLAN_SEC_WPA2

#define IDLE_TIMEOUT_MS  2000
#define TCP_TIMEOUT      3000

#define WEBSITE         "api.xively.com"
#define API_key         "Nm8vxZaYtkCreW9oBL74VIxY93ONHsvNlpizj6QkIM8hxxxx" // Updat
e Your API Key
#define feedID         "180220xxxx"         // Updat
e Your own feedID

void setup(){

  Serial.begin(115200);
  Serial.println(F("Hello, CC3000!\n"));

  /* Initialise the module */
  Serial.println(F("\nInitialising the CC3000 ..."));
  if (!Wido.begin())
  {

```

```

    Serial.println(F("Unable to initialise the CC3000! Check your wiring?"));
    while(1);
}

/* Attempt to connect to an access point */
char *ssid = WLAN_SSID;          /* Max 32 chars */
Serial.print(F("\nAttempting to connect to "));
Serial.println(ssid);

/* NOTE: Secure connections are not available in 'Tiny' mode!
By default connectToAP will retry indefinitely, however you can pass an
optional maximum number of retries (greater than zero) as the fourth param
eter.
*/
if (!Wido.connectToAP(WLAN_SSID, WLAN_PASS, WLAN_SECURITY)) {
    Serial.println(F("Failed!"));
    while(1);
}

Serial.println(F("Connected!"));

/* Wait for DHCP to complete */
Serial.println(F("Request DHCP"));
while (!Wido.checkDHCP())
{
    delay(100); // ToDo: Insert a DHCP timeout!
}

}

uint32_t ip = 0;    // Store Xively ip address
float temp = 0;    // Store temporary sensor data for post

void loop(){

```

```

static Adafruit_CC3000_Client WidoClient;

static unsigned long RetryMillis = 0; // timer stamp for building the connection

static unsigned long uploadtStamp = 0; // timer stamp for posting data to service

static unsigned long sensortStamp = 0; // timer stamp for reading data to LM35

// Apply for the connection with the cloud service

if(!WidoClient.connected() && millis() - RetryMillis > TCP_TIMEOUT){
    // Update the time stamp
    RetryMillis = millis();

    Serial.println(F("Try to connect the cloud server"));

    //Get Xively IOT Server IP
    ip = Wido.IP2U32(216,52,233,120);
    WidoClient = Wido.connectTCP(ip, 80);
}

// After building the connection with the service
// Post the sensor data to Xively
if(WidoClient.connected() && millis() - uploadtStamp > 2000){
    uploadtStamp = millis();

    // If the device is connected to the cloud server, upload the data every 2000ms.

    // Prepare JSON for Xively & get length
    int length = 0;
    // JSON beginning
    String data_start = "";
    data_start = data_start + "\n"
        + "{\"version\":\"1.0.0\",\"datastreams\" : [ ";

```

```

// JSON for temperature & humidity
String data_temperature = "{\"id\" : \"Temperature\", \"current_value\" :
\""
    + String(int(temp)) + "\"}]]";
// Get length
length = data_start.length() + data_temperature.length();

Serial.println(F("Connected to Xively server.));

// Send headers
Serial.print(F("Sending headers"));
WidoClient.fastrprint(F("PUT /v2/feeds/"));
WidoClient.fastrprint(feedID);
WidoClient.fastrprintln(F(".json HTTP/1.0"));
Serial.print(F("."));
WidoClient.fastrprintln(F("Host: api.xively.com"));
Serial.print(F("."));
WidoClient.fastrprint(F("X-APIKey: "));
WidoClient.fastrprintln(API_key);
Serial.print(F("."));
WidoClient.fastrprint(F("Content-Length: "));
WidoClient.println(length);
Serial.print(F("."));
WidoClient.fastrprint(F("Connection: close"));
Serial.println(F(" done.));

// Send data
Serial.print(F("Sending data"));
WidoClient.fastrprintln(F(""));
WidoClient.print(data_start);
Serial.print(F("."));
WidoClient.print(data_temperature);
Serial.print(F("."));
WidoClient.fastrprintln(F(""));

```

```

Serial.println(F(" done."));

/* Get the http page info
Serial.println(F("Reading answer..."));
while (WidoClient.connected()) {
  while (WidoClient.available()) {
    char c = WidoClient.read();
    Serial.print(c);
  }
}
*/
delay(1000);          // Wait for 1s to finish posting the data stream
WidoClient.close();   // Close the service connection
RetryMillis = millis(); // Reset the timer stamp for applying the connection with the service
}

//Realtime update the latest sensor data from LM35 once per 100ms and convert the unit (degree)
if(millis() - sensortStamp > 100){
  sensortStamp = millis();
  // read the LM35 sensor value and convert to the degrees every 100ms.

  int reading = analogRead(0);
  temp = reading *0.0048828125*100;
  Serial.print(F("Real Time Temp: "));
  Serial.println(temp);
}
}

```

4. Then Wido will upload the sensor data to the cloud once every 2s. You could check the Request Log and the Channel info from the device page now.

Step 2

The Adafruit library for CC3000 is really good and extending lots of feature for the WG1300. This library is also modified based on the TI smartlink solution.

Here're some simple introduction for the functions commonly used!

1. Trick for saving the programming space. The ATmega32U4 programming space is limited. So call the feature is really useful for your program.

```
#define CC3000_TINY_DRIVER
```

The code above will launch the tiny driver function.

2. Initialise the module.

```
if (!cc3000.begin())
{
    Serial.println(F("Unable to initialise the CC3000! Check your wiring?"));
    while(1);
}
```

3. Setup the router connection!

```
if (!cc3000.connectToAP(WLAN_SSID, WLAN_PASS, WLAN_SECURITY)) {
    Serial.println(F("Failed!"));
    while(1);
}
```

4. Finish and get the DHCP info from the router/AP

```
while (!cc3000.checkDHCP())
{
    delay(100); // ToDo: Insert a DHCP timeout!
```

```
}
```

Part 2-4 the key steps to access the network.

Trouble shooting

More question and cool idea, [visit DFRobot Forum](#)